

ASSEMBLY INSTRUCTIONS

REMOVE CARRIAGE BOLT WHEEL ASSEMBLY. SLIDE CAP ASSEMBLY INTO WHEEL ASSEMBLY AND RE-ATTACH CARRIAGE BOLT, ADJUST AS NECESSARY.

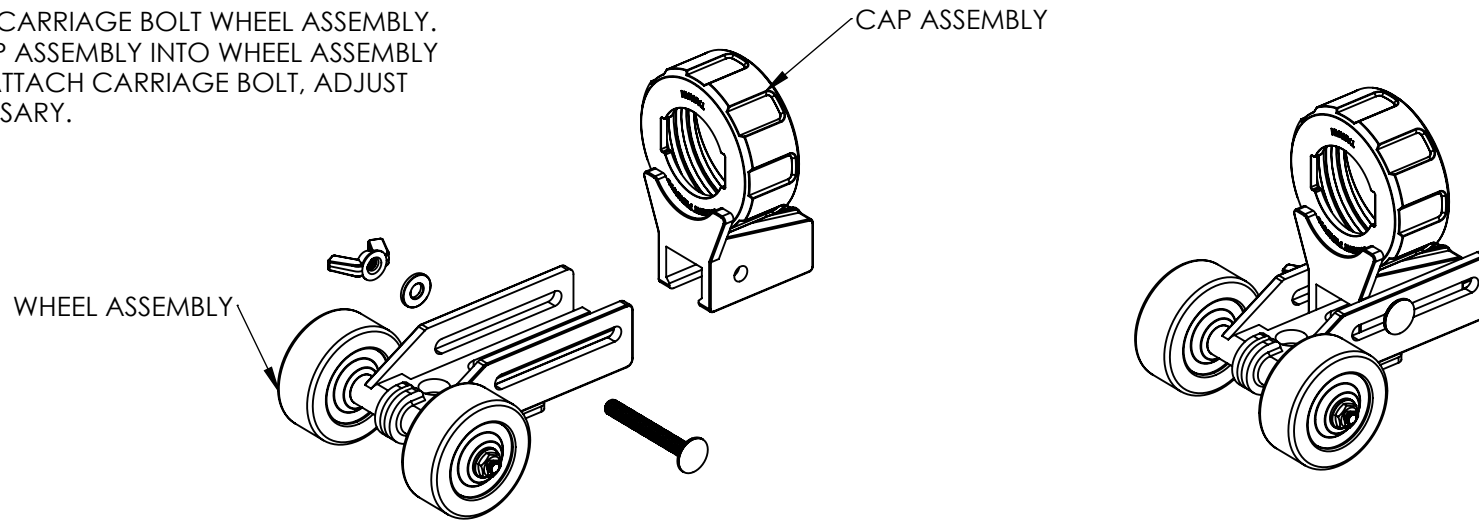

TO USE JOINT FOLLOWER REMOVE SCREW FROM THE BOTTOM OF TOOL. INSERT JOINT FOLLOWER ONTO THE FRONT OF WHEEL ASSEMBLY.

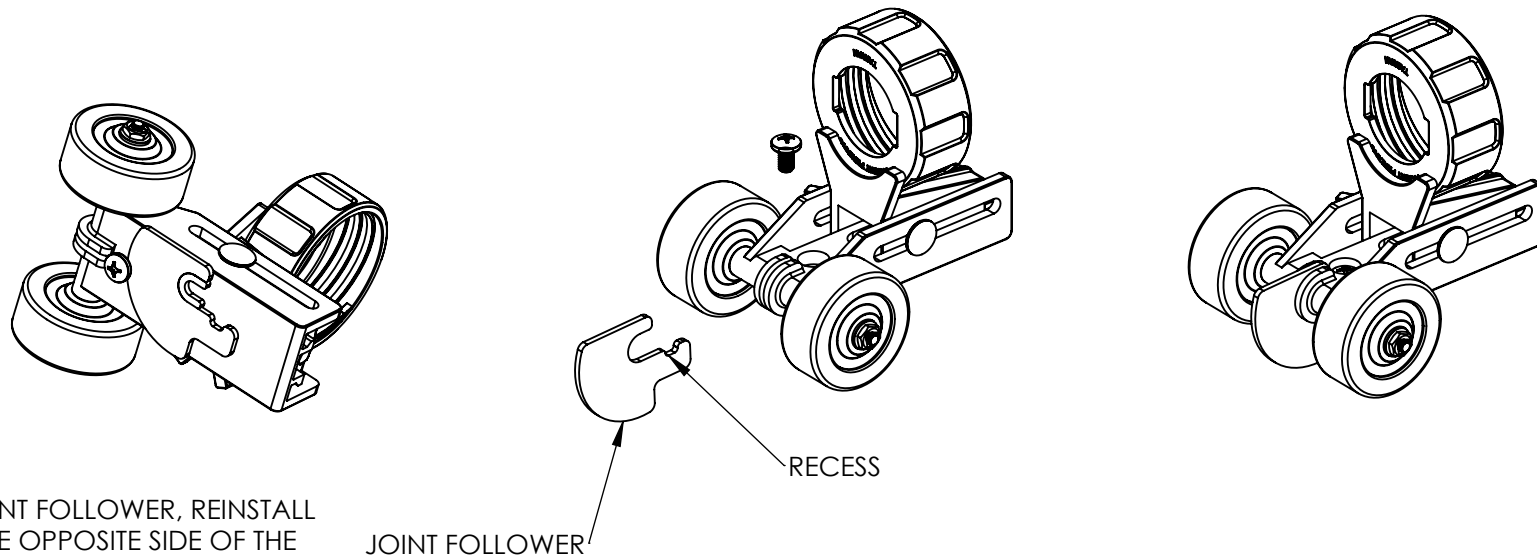

TO RETAIN JOINT FOLLOWER, REINSTALL SCREW ON THE OPPOSITE SIDE OF THE HOLE, MAKING SURE THE SCREW THREAD IS LOCATED INSIDE THE RECESS OF THE JOINT FOLLOWER.