

Steps:

1. Lube o-rings with grease.
2. Insert union tube into casting.
3. Assemble main handle into union tube.
4. Insert handle nuts into main handle.
5. Insert screws into main handle and tighten.
6. Align holes in upper handle assembly with holes in casting. Insert upper handle screws into castings. Upper handle can be adjusted by loosening main nut.

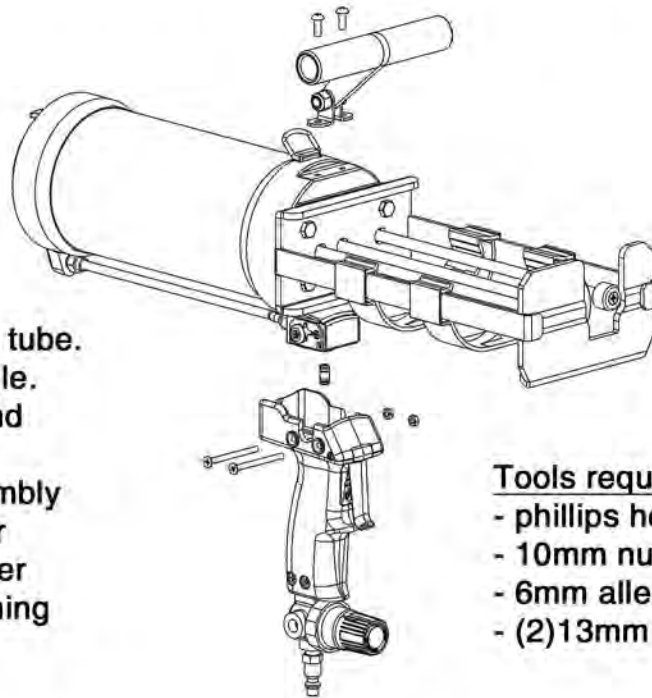

Tools required

- phillips head screwdriver
- 10mm nut driver
- 6mm allen wrench
- (2) 13mm nut drivers

Step 1

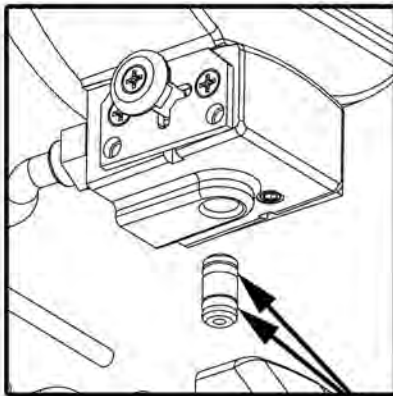

o-rings

Step 2

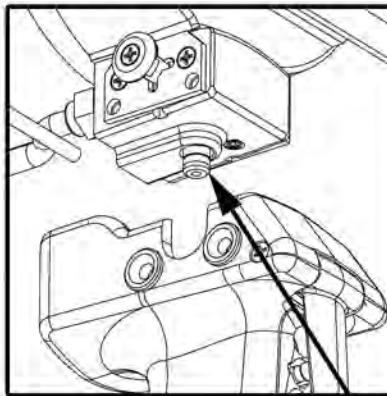

union tube

Step 3

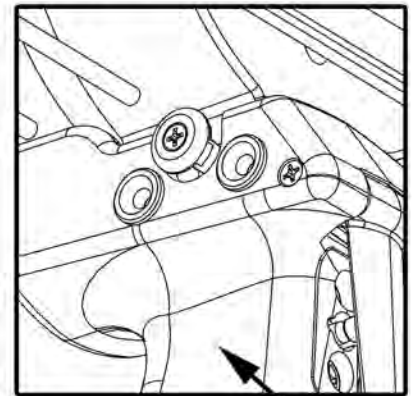

main handle

Step 4

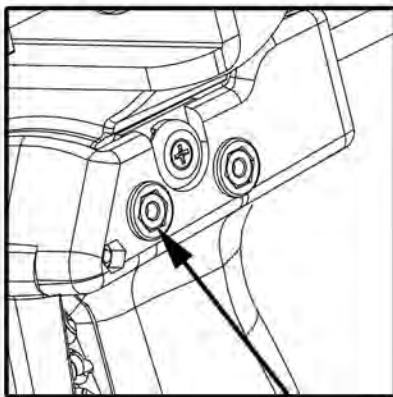

handle nuts

Step 5

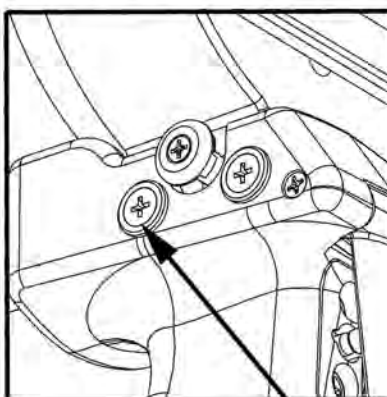

handle screws

Step 6

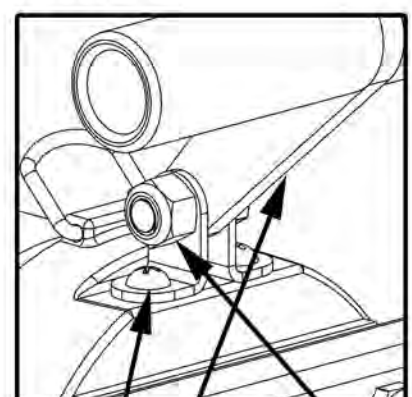

screws
upper handle assembly

main nut
(13mm)

AT-Line Suitcase handle assembly instructions

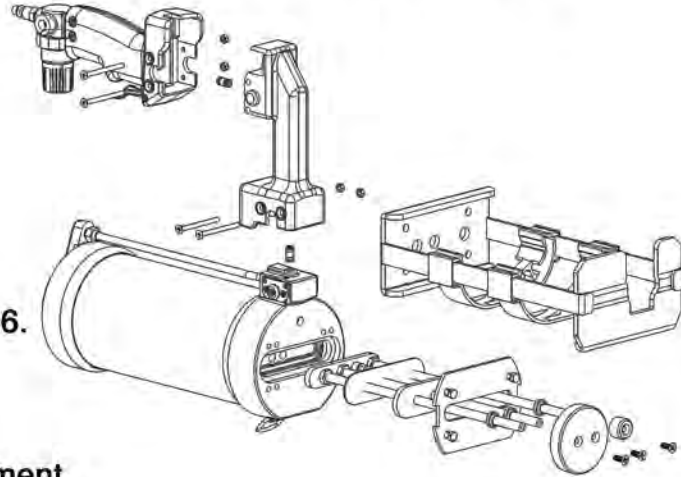
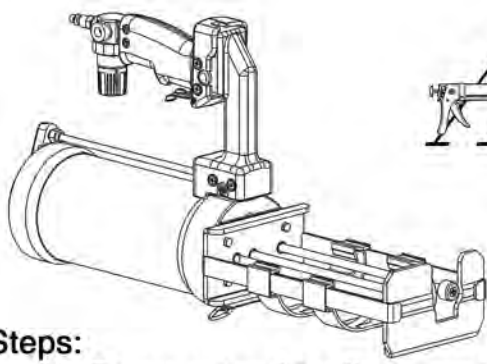

Steps:

1. Remove top handle assembly.
2. Remove ejectors & carriage (note ejector relation to rods.).
3. If cartridge ratio is not 1:1, remove rod assembly by loosening piston bolt. If ratio is 1:1 move on to step 6.
4. Rotate piston 180 degrees.
5. Rotate rod assembly 180 degrees and assemble.
6. Rotate carriage 180 degrees and re-attach.
7. Reassemble ejectors to rods noting their correct placement.
8. Unscrew main handle leaving the union tube in place.
9. Attach suitcase handle using handle nuts and screws.
10. Lube o-rings with grease and insert union tube into suitcase handle.
11. Attach main handle to suitcase handle using handle nuts and screw.

Step 1

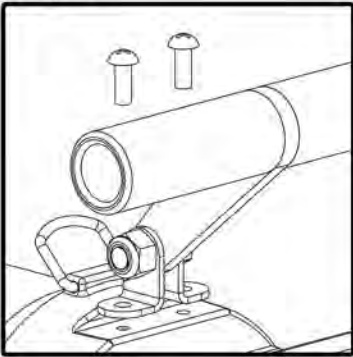

Step 2

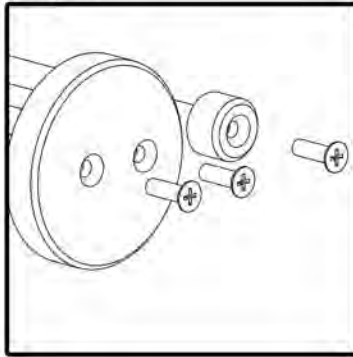

Step 2

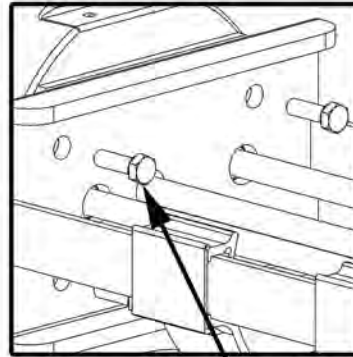

Step 3

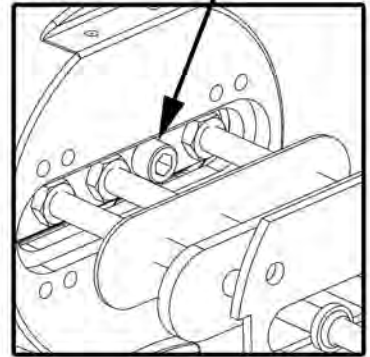

Step 4

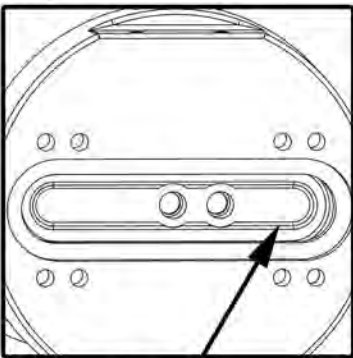

Step 5

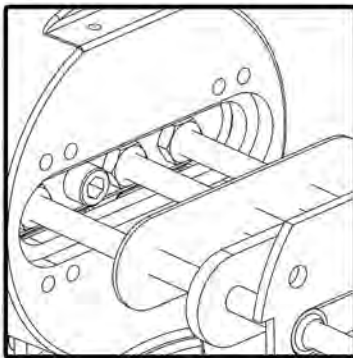

Step 6

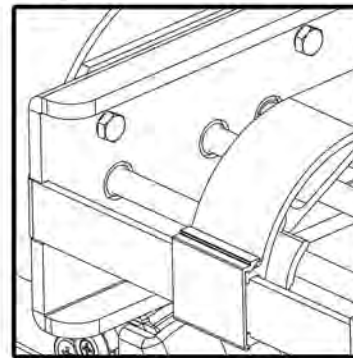

Step 7

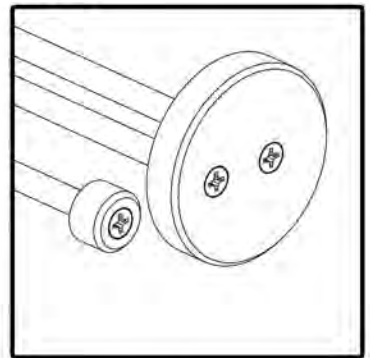

Step 8

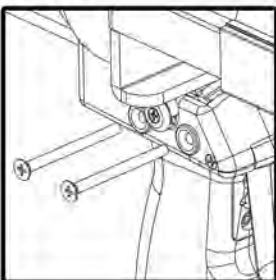

Step 8

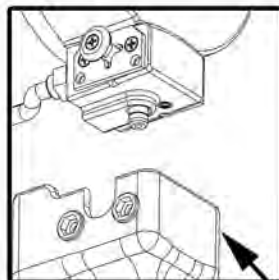

Step 9

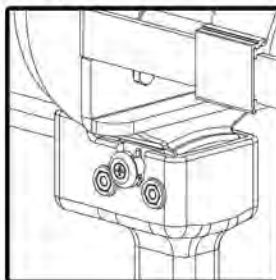

Step 10

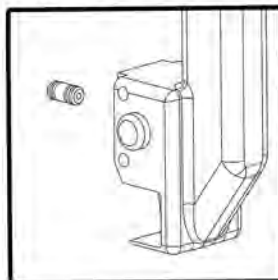

Step 11

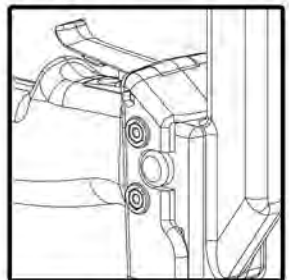

piston bolt (6mm)

carriage bolt (10 mm)

piston

suitcase handle



Albion Engineering Company
1250 N. Church Street
Moorestown, New Jersey 08057
Phone: 856-235-6688 Fax: 856-235-9460
www.albioneng.com

AT-Line Operating Instructions

Safety

- 120psi maximum operating pressure.
- Do not drop or let anything drop on the applicator.
- Do not damage or polish the piston rods.
- Store in a clean dry environment.
- Eye protection must be worn at all times when the applicator is in operation.
- Do not point the applicator at anyone while the tool is in operation.
- Do not place any part of your body either inside or in front of the material chambers while the applicator is connected to an air supply.
- Read the material safety data sheets (MSDS) on the material being used.

Cleaning

Keeping the applicator clean is important for long life and trouble free operation. Due to the tool's rugged construction, most solvents can be used to remove material. It is not recommended to immerse the tool in a cleaning agent, as this may adversely affect the internal seals of the applicator. Special care should be taken to ensure no material residue is left on the piston rods.

General dispensing instructions

Note: It is highly recommended that you advance and retract the pistons in an empty applicator until you are comfortable with its operation.

The dispensing rate of the applicator is determined by the air pressure used. It is advised to begin at the lowest pressure setting and adjust the pressure to your desired speed.

Twin Cartridge Models

To load twin cartridges:

1. Note: for models that include multi-ratio kits, verify that the proper piston ejectors and cartridge retainers are installed for the cartridge to be dispensed.
2. Retract the piston rods by switching the forward/reverse button and then actuate the trigger to allow the rods to travel back into the barrel.
3. Insert the cartridge into the applicator, making sure the cartridge is secured into the plastic cartridge retainer(s).
4. Ensure that the front of the cartridge is seated against the applicator's front plate before dispensing.

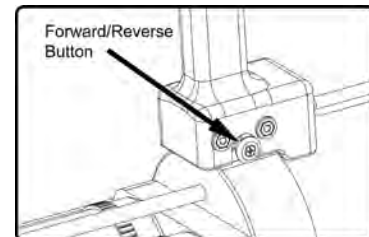

To dispense twin cartridges:

1. Remove caps and/or plugs from the cartridge and install a new static mixer on the end of the cartridge. Some static mixers require a plastic nut to secure it to the cartridge.
2. With the regulator at low pressure, switch the forward/reverse button to the forward position and then actuate the trigger to allow the rods to travel forward to ensure the piston ejectors are properly seated against the cartridge pistons.
3. Do not apply adhesive to the work area until the proper mixture is exiting the static mixer.
4. To adjust the material flow, actuate the trigger and adjust the air pressure with the regulator until your desired dispensing rate is achieved.
5. To stop dispensing, release the trigger to exhaust the air pressure within the tool.
6. Note: Mixed compounds will harden in the static mixer if left unused for a few minutes. To prevent rupturing of the cartridge, replace the static mixer.

Twin Sausage Pack Models

To load twin sausage packs into the chamber:

1. Retract the piston rods by switching the forward/reverse button and then actuate the trigger to allow the rods to travel back into the barrel.
2. Rotate the swivel carriage out of the way so the aluminum manifold can be removed from the twin chambers.
3. Remove front retainer from sausages and insert sausages into the barrel with their opening facing towards the outside of the chambers. Note: ensure that the same sausage material is inserted into the same chamber every time to prevent a clogged system.
4. Insert aluminum manifold into the chambers until the flat portion of the manifold butts up to the barrel ends. Note: ensure that the manifold is inserted into the same chamber every time to prevent a clogged system.
5. Rotate swivel carriage over manifold so that its face sits evenly with the manifold face. Note: when dispensing, the chamber section of the manifold should not have a gap of more than 1/16" past the face of the barrel, as material leakage may result. The chambers can be adjusted by rotating them until the correct distance is achieved.

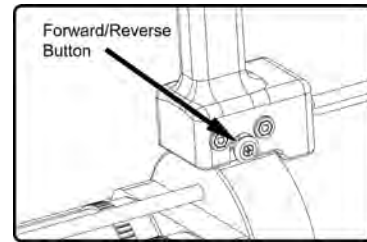

To dispense twin sausage packs:

1. Insert a static mixer onto the manifold. The manifold accepts standard 3/4NPS and NPT type threads.
2. Lower the applicator to the desired work area and switch the forward/reverse button to dispense material. Actuate the trigger and increase the air pressure while dispensing material until the desired dispensing rate is achieved.
3. While dispensing, note that the indicator rod is also advancing. When the sausages are empty, release the trigger to exhaust the air pressure within the tool.
4. Remove the empty sausages from the chambers by rotating the swivel carriage and removing the manifold. Actuate the trigger to remove the empty sausages.